

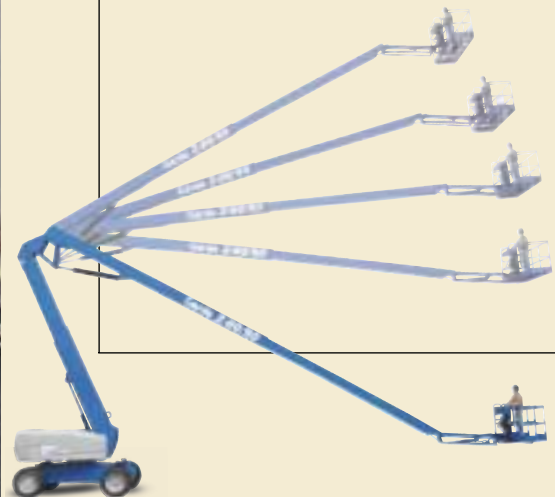

Self-Propelled Articulating Boom

Z-80/60™

○ Industry leading range of motion, enhanced with Genie's new innovative lift structure, increases operator productivity



Genie Industries

Standard Features

- 26.4 m (86 ft) working height
- 18.3 m (60 ft) outreach
- 8.8 m (29 ft) up and over clearance
- 1.83 m (6 ft) jib boom with 128° range of motion
- 2.44 m (8 ft) steel platform
- 227 kg (500 lb) lift capacity
- Oscillating front axle
- Dual fuel (Gas/LPG) or diesel engine options
- Fully proportional platform controls with ramp up/down feature
- Hydraulic platform rotation
- 360° continuous turntable rotation
- 12V DC auxiliary power unit
- Full time positive traction drive

Full time 4WD (on 4WD models)

- Closed-loop hydrostatic drive
- Hydraulic Oil Cooler
- Drive enable system
- Self-levelling platform
- Onboard full diagnostics
- Anti-restart engine protection
- Auto engine fault shutdown
- Engine monitoring display
- AC wiring to platform
- High-angle steer
- Extra Wide RT foam-filled tyres
- Wire braided hydraulic hoses
- Tilt alarm
- Horn
- Hour meter

4 Wheel Steer & Oscillating axle



Options and Accessories

- Two or Four-wheel drive models
- Two or Four-wheel steer options
- Liquid cooled or Air cooled diesel engines
- Alarm package
- Cold start packages
- Onboard welder packages
- 2500 watt & 4000 watt AC generator
- Air line to platform
- Weld cables to platform
- Hostile environment packages
- Platform work lights
- Platform swing gate

Range of Motion

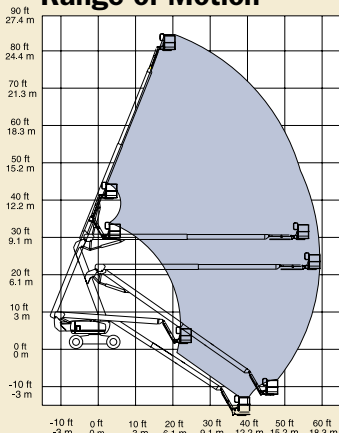

- Platform rail pinch guard
- Control box covers
- Driving lights
- LPG tank
- Second LPG tank with carrier
- Tool tray

Standards Compliance

- ANSI/SIA A92.5
- CE compliance option
- CSA CAN3-B354.4-M82
- AS 1418.10

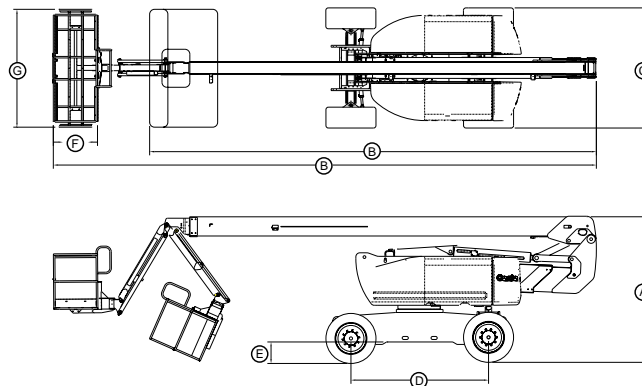

Specifications

	Metric	US
Working height max*	26.4 m	86 ft
Platform height max	24.4 m	80 ft
(A) Height - stowed	3 m	9 ft 10 in
(B) Length - stowed	11.27 m	37 ft
Length - transport	9.14 m	30 ft
(C) Width	2.49 m	8 ft 2 in
(D) Wheelbase	2.74 m	9 ft
(E) Ground clearance	30 cm	12 in
(F) Platform length:	91 cm	36 in
(G) Platform width:	2.44 m	96 in
Horizontal reach max	18.3 m	60 ft
Up and over clearance	8.83 m	29 ft
Lift capacity	227 kg	500 lb
Turning radius – 4WS, inside	2.1 m	7 ft
– 4WS, outside	4.6 m	15 ft
– 2WS, inside	4.4 m	14 ft 6 in
– 2WS, outside	7.5 m	24 ft 6 in
Turntable rotation	360° continuous	
Tailswing – elevated position	91.4 cm	3 ft
Power source	Deutz Diesel F4L 913 57 kw (77 hp) air cooled Perkins Diesel 704-30 47 kw (63 hp) liquid cooled GM 3.0L Gas/LPG 60 kw (80 hp)	
Drive speed – stowed	4.82 km/h	3.0 mph
Drive speed – raised ¹	1 km/h	0.6 mph
Controls	12V DC proportional	
Platform rotation	160°	160°
Auxiliary power unit	12V DC	
Tyres - foam filled	18x19.5	
Gradeability ² - 2WD	30%	30%
- 4WD	50%	50%
Hydraulic tank capacity	170 litre	45 gal
Fuel tank capacity	125 litre	33 gal
Weight** - 2WS	16284 kg	35900 lbs.
- 4WS	16580 kg	36552 lbs.

1 In lift mode (platform raised), the machine is designed for operation on firm level surfaces only.
2 Stowed position only.

* The metric equivalent of working height adds 2 m to platform height. U.S. adds 6 ft to platform height.
** Weight will vary depending on options and/or country standards.

Distributed By:

Genie Industries™

GENIE AUSTRALIA
591 Boundary Road, Darra Qld 4076
PO Box394, Richlands Qld 4077
Telephone **07 3375 1660**
Fax 07 3375 1002
<http://www.genieindustries.com>

GENIE UNITED STATES
18340 NE 76th Street, P.O. Box 97030
Redmond, Washington 98073-9730
Telephone **(425) 881-1800**
Toll Free in USA/Canada **800-536-1800**
Fax (425) 883-3475
<http://www.genieindustries.com>