



Self-Propelled Aerial Work Platform

Runabout™

A compact machine with low overall weight.



Genie Australia
GENIE MEANS MORE THAN LIFTING

Genie Runabout™

- The Runabout features Genie's **patented mast system** with high strength interlocking aluminium mast sections and heavy duty lifting chains.
- Narrow 75 cm (29½ in) width and 1.35 m (53 in) length **allow unit to fit in most passenger elevators.**
- Low 48 cm (19 in) entry height allows operators to enter the platform easily. **Unit can be driven through doorways with operator on board.**
- Optional platform extension deck provides 51 cm (20 in) of horizontal outreach.
- Standard non-marking tyres and low unit weight **allow use on sensitive flooring.**

- Standard dual wheel spring-applied, hydraulically released braking system.
- **All models are driveable when fully elevated.** GR-8 and GR-12 models can be driven when fully elevated with the optional platform extension deck deployed. GR-15 can be driven when fully elevated with the optional extension deck retracted.

Standard Features

- 227 kg (500 lb) lift capacity on GR-8, GR-12; 159 kg (350 lb) lift capacity on GR-15
- 24V DC electric motor provides clean power for indoor use
- High battery amp hour rating provides prolonged usage between charges
- 25 amp automatic charger for easy overnight recharging
- Proportional drive controls
- 30% gradeability
- Standard platform with basic sliding midrail
- Fixed pothole protection
- Forklift pockets and tie-down points
- Non-marking solid rubber tyres
- Descent and tilt alarms
- Work station tray

Options and Accessories

- Platform extension deck with gated-entry platform
- Fluorescent tube caddy
- 1,000 watt inverter
- Mastguard (in lieu of work station tray)

Standards Compliance

ANSI/SIA A92.6
 CE compliance option
 AS 1418.10
 CSA – Call factory for details

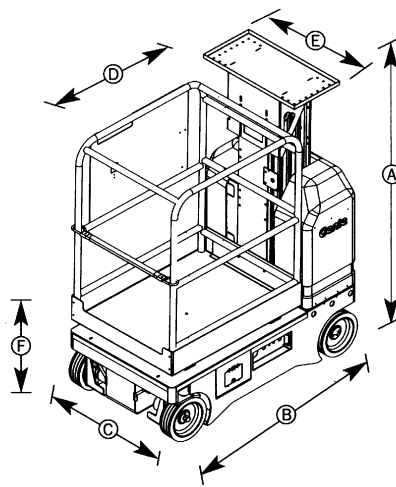

Specifications

Model	GR-8		GR-12		GR-15	
	Metric	US	Metric	US	Metric	US
Working height ¹	4.54 m	14 ft 4 in	5.58 m	17 ft 9 in	6.62 m	21 ft 2 in
Platform height	2.54 m	8 ft 4 in	3.58 m	11 ft 9 in	4.62 m	15 ft 2 in
Ⓐ Height – stowed						
ANSI with work station tray	1.71 m	67 ½ in	1.71 m	67 ½ in	1.71 m	67 ½ in
ANSI with mastguard	1.66 m	65 ½ in	1.66 m	65 ½ in	1.66 m	65 ½ in
CE with work station tray	1.79 m	70 ½ in	1.79 m	70 ½ in	1.79 m	70 ½ in
CE with mastguard	1.79 m	70 ½ in	1.79 m	70 ½ in	1.79 m	70 ½ in
Ⓑ Length	1.35 m	53 in	1.35 m	53 in	1.35 m	53 in
Ⓒ Width	75 cm	29 ½ in	75 cm	29 ½ in	75 cm	29 ½ in
Ⓓ Platform length	94 cm	37 in	94 cm	37 in	94 cm	37 in
Ⓔ Platform width	75 cm	29 ½ in	75 cm	29 ½ in	75 cm	29 ½ in
Platform length – extended	1.45 m	57 in	1.45 m	57 in	1.45 m	57 in
Platform extension length	51 cm	20 in	51 cm	20 in	51 cm	20 in
Ⓕ Platform entry height	48 cm	19 in	48 cm	19 in	48 cm	19 in
Lift capacity	227 kg	500 lb	227 kg	500 lb	159 kg	350 lb
Extension deck capacity	113 kg	250 lb	113 kg	250 lb	113 kg	250 lb
Turning radius – outside	1.57 m	62 in	1.57 m	62 in	1.57 m	62 in
Turning radius – inside	15 cm	6 in	15 cm	6 in	15 cm	6 in
Power source	24V (4 6V 205AH batteries) (All models)					
Drive speed – stowed	4 km/h	2.5 mph	4 km/h	2.5 mph	4 km/h	2.5 mph
Drive speed – raised	0.8 km/h	0.5 mph	0.8 km/h	0.5 mph	0.8 km/h	0.5 mph
Raise/lower speed	15/20 sec		18/20 sec		20/20 sec	
Gradeability	30%		30%		30%	
Weight	658 kg	1,450 lb	748 kg	1,650 lb	975 kg	2,150 lb

¹The metric equivalent of working height adds 2m to platform height. U.S. adds 6ft to platform height.

Distributed By:

Genie Industries™

GENIE AUSTRALIA

591 Boundary Road, Darra Qld 4076
 PO Box 394, Richlands Qld 4077
 Telephone **07 3375 1660**
 Toll Free in Australia **1800 331 660**
 Fax 07 3375 1002
<http://www.genieindustries.com>

GENIE UNITED STATES

18340 NE 76th Street
 P.O. Box 97030
 Redmond, Washington 98073-9730
 Telephone **425 881 1800**
 Toll Free in USA/Canada **800 536 1800**
 Fax 425 883 3475
<http://www.genieindustries.com>