

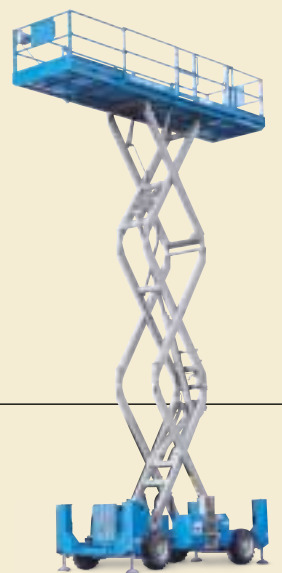

Rough Terrain Self-Propelled Scissor Lift

GS™-3384 RT

○ The ultimate scissor lift for narrow, rough terrain applications.



Genie Industries

GS-3384 RT

- Large platform with **durable diamond-plate aluminum flooring**.

A **single 1.52 m (60 in) multi-position slide-out extension deck**, on the front of the machine, **comes standard**.

A second 1.22 m (48 in) slide-out extension deck, on the rear of the machine, is available as an option.

- Slide-out engine tray allows **easy access to components**.
- Optional **automatic levelling hydraulic outriggers**

Standard Features

- 12.1 m (39 ft) working height
- 1,134 kg (2,500 lb) platform capacity
- Front platform extension deck
- Positive traction-control
- 50% gradeability
- Proportional drive
- Powered by GM Gas/LPG engine (standard) or Deutz Diesel engine (optional)
- Slide-out engine tray for easy maintenance
- Foam-filled tyres
- AC wiring to platform
- Descent alarm
- Tilt sensor with an audible alarm
- Horn
- Hour meter

Options and Accessories

- Automatic levelling hydraulic outriggers
- Rear extension deck
- Hydraulic oil cooler
- 2,500 watt generator (240 Volt/50 hz)

Standards Compliance

- ANSI/SIA A92.6
- AS 1418.10
- CE compliance option
- CSA CAN3-B354.2-M82

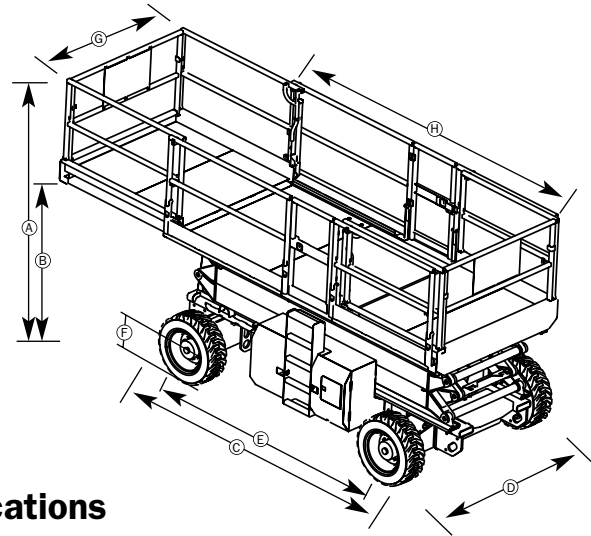

Specifications

Model **GS-3384 RT**

	Metric	US
Working height*	12.1 m	39 ft
Platform height	10.1 m	33 ft
(A) Height - stowed		
guardrails	268 cm	105.5 in
guardrails lowered	200 cm	78.75 in
(B) Height - stowed (platform)	155 cm	61 in
(C) Length		
stowed	394 cm	155.25 in
stowed-w/outriggers	488 cm	192 in
single deck extension	540 cm	212.5 in
w/ dual deck extension	657 cm	258.5 in
(D) Width-standard tyres	213 cm	84 in
(E) Wheelbase	288 cm	113.5 in
(F) Ground clearance	33 cm	13 in
(G) Platform width	1.83 m	72 in
(H) Platform length		
single deck extended	5.4 m	212.5 in
dual deck extended	6.57 m	258.5 in
Lift capacity	1,134 kg	2,500 lb
Extension deck capacity (max)	227 kg	500 lb
Turning radius - outside	594 cm	234 in
Turning radius - inside	309 cm	121.5 in
Power source	GM 1.6L 39 kw (52 hp), water cooled dual fuel Deutz Diesel F3L 1011 31 kw (42 hp), air cooled	
Auxiliary power unit	12 volt DC	
Drive speed - stowed	6.4 km/h	4 mph
Drive speed - raised	1.1 km/h	0.7 mph
Raise/lower speed	45/29 sec	
Tyres - rough terrain	25.4 cm x 41.9 cm	10 in. x 16.5 in
Gradeability (4x4)	50%	
Hydraulic tank capacity	75.7 litre	20 gal
Fuel tank capacity	75.7 litre	20 gal
Weight**	6243 kg	13,764 lb

* The metric equivalent of working height adds 2 m to platform height. U.S. adds 6 ft to platform height.

** Weight will vary depending on options and/or country standards.

Distributed By:

Genie Industries™

GENIE AUSTRALIA

591 Boundary Road, Darra Qld 4076
PO Box 394, Richlands Qld 4077
Telephone **07 3375 1660**
Fax 07 3375 1002
<http://www.genieindustries.com>

GENIE UNITED STATES

18340 NE 76th Street, P.O. Box 97030
Redmond, Washington 98073-9730
Telephone **(425) 881-1800**
Toll Free in USA/Canada **800-536-1800**
Fax (425) 883-3475
<http://www.genieindustries.com>